

ALUMINCO[®]

**INNOVATIVE
EXTRUDED
SOLUTIONS**



**WE
ARE
GLOBAL**



53%
exports

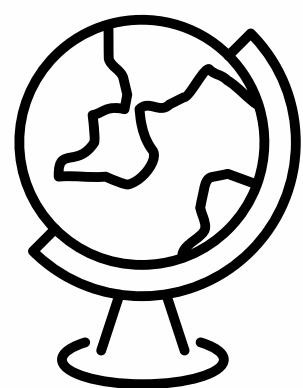

60
countries



2500
POS

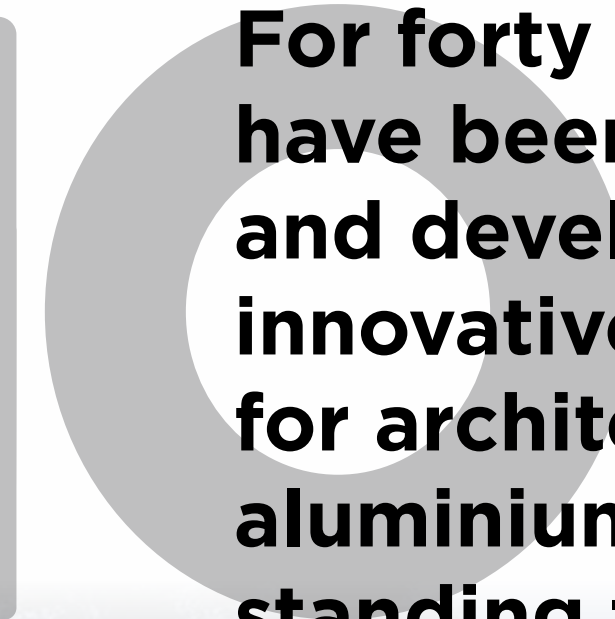

**For forty years we
have been designing
and developing
innovative solutions
for architectural
aluminium systems,
standing for Greek
quality, in more than
60 countries.**



1982- >>

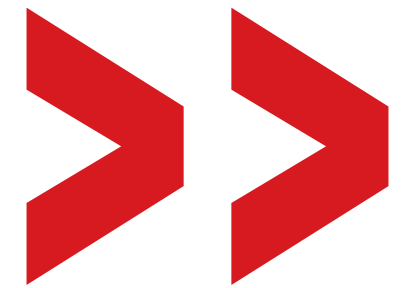

1982

Theodoros Karras founds the company in a small foundry. With limited resources and exceptional passion, he produces cast aluminium railings and a wide range of products.

1990

The company is growing dynamically, evolving its product portfolio and expanding its export network. It becomes the 1st company in Greece to produce aluminium doors and panels.

2002

ALUMINCO is expanding into new privately owned 60,000 square metres facilities in Inofita, Viotia. At the same time, in response to the constant demands of the market for energy saving and thermal insulation, ALUMINCO develops the first series of thermal-insulating aluminum profiles.

2003

ALUMINCO acquires privately owned and state-of-the-art facilities of 60,000 sq.m. in Inofita, Viotia. It is equipped with the 1st extrusion line and develops the 1st range of thermal insulated profiles for aluminium doors & windows.

2006

A planet to Love, adopting sustainable solutions throughout its turnover. Installation of a 1.2 MWp photovoltaic system on our industrial property, reducing carbon dioxide emissions by 1925 tons per year.

2015

The baton of the company passes to the new generation of entrepreneurs and a new investment plan of 7.8 million euros is announced.

2017

New industrial investments in production plants, such as the 2nd extrusion line for the production of a new generation of architectural & industrial profiles, a vertical electrostatic painting unit and new robotic profile and matrix warehouses.

2018

The group's exports exceed 55% of the total turnover, which amounts to 40 million euros.

2020

The imposing, special design, facade system, ALUMINCO SKG120 "dresses" the new terminal of the airport of Thessaloniki, highlighting innovation and design in complex projects of extreme requirements.

2021

Acquisition of aluminium extrusion in Northern Greece and installation of a new extrusion line (3rd in order) in Inofita of Viotia. The skyline series of premium aluminum systems is launched. The international standard ISO 50001, that helps reduce energy consumption and minimize carbon footprint, promoting sustainable energy use, is implemented.

2022

The photovoltaic system on our industrial property produces 2.2 Mwp, reducing carbon dioxide emissions by 1925 tons per year.

KEY PERFORMANCE INDICATORS

% INTERNATIONAL SALES / GROUP SALES

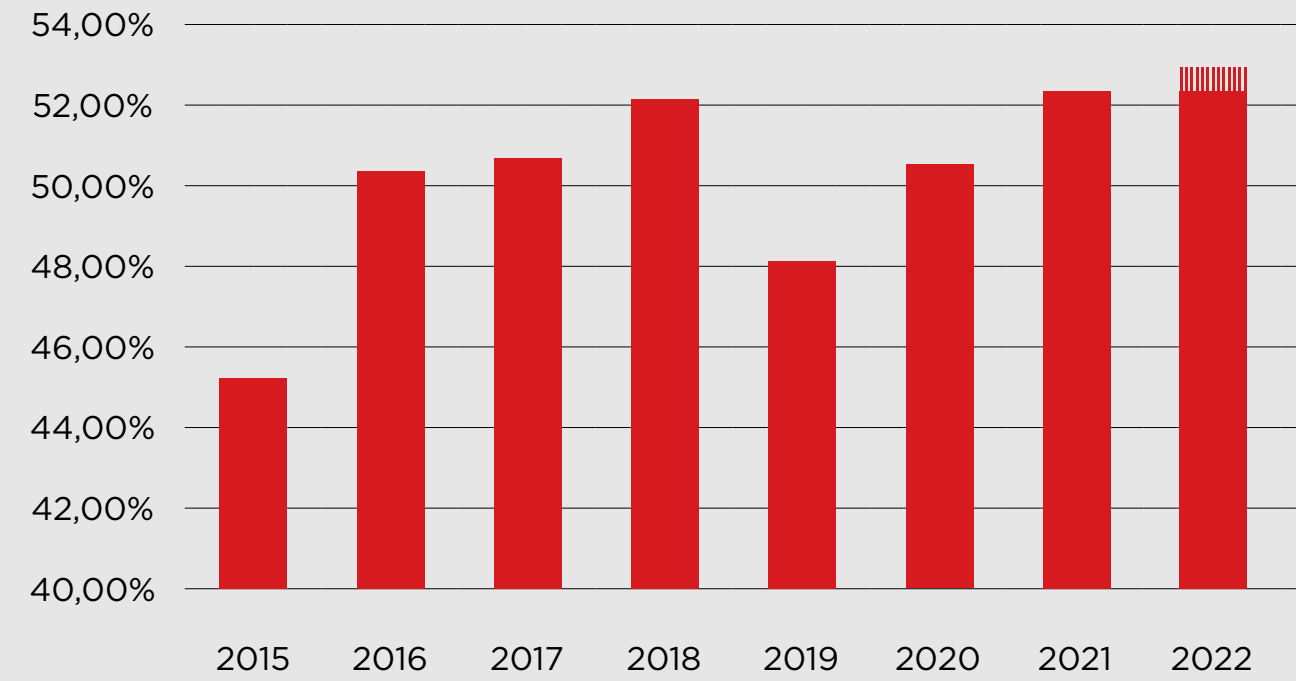

INVESTMENTS

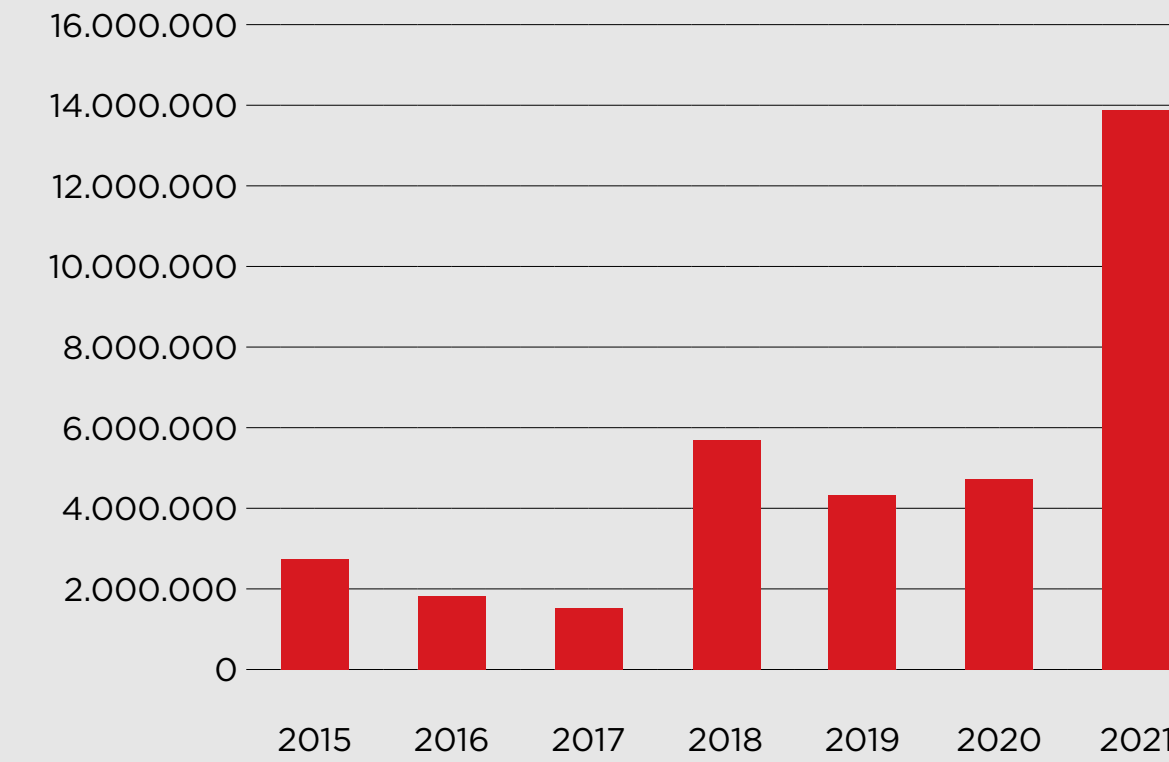

GROUP & INTERNATIONAL SALES

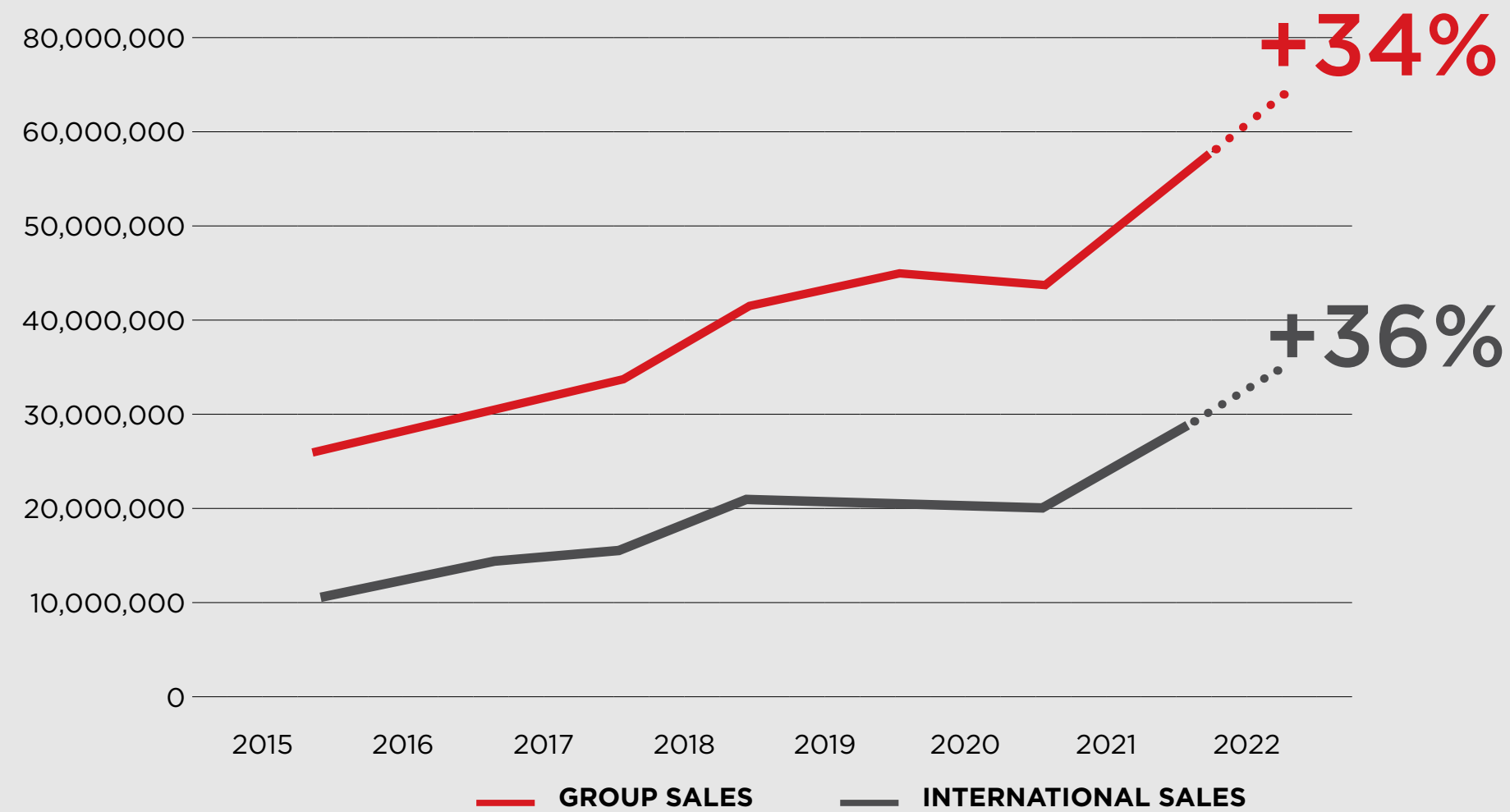

Group Sales, based on the forecast for 2022, will grow by 34%, while the share of exports, again based on the forecast for 2022, will increase by 36%.

EBITDA

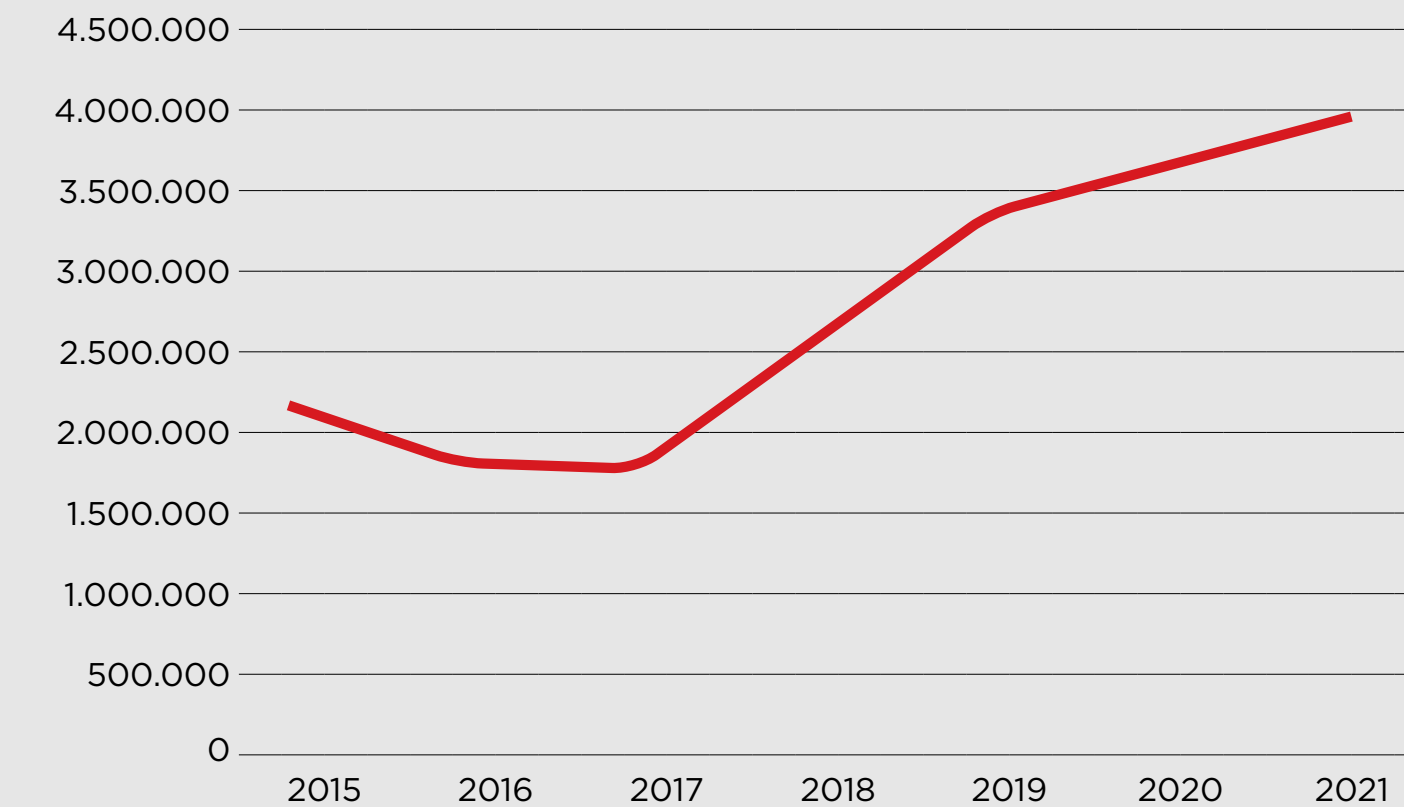

WE ARE CAPABLE OF EVERYTHING

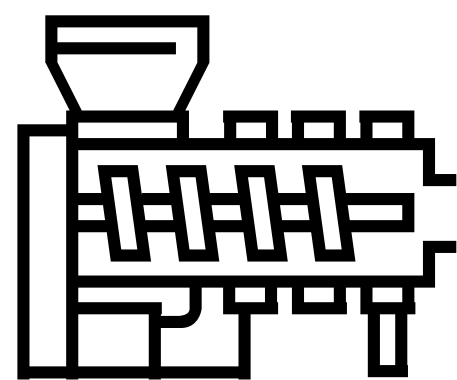

4

aluminium extrusion lines
with a production capacity of
over 35,000 tons of aluminium
profiles per year

ALUMINCO



SURFACE TREATMENT METHODS THAT STRENGTHEN THE ADVANTAGES OF ALUMINIUM

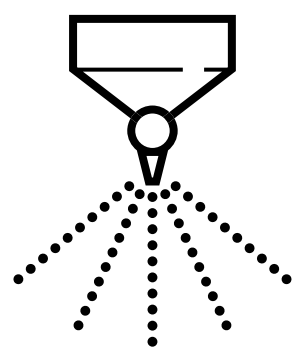

6

powder coating lines

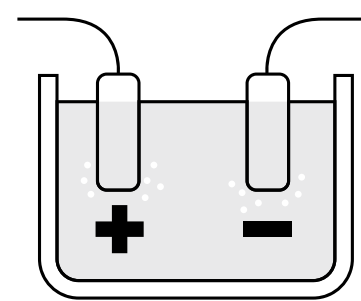

1

anodizing line

ALUMINCO



WE CONTROL THE ENTIRE PROCESS FROM EXTRUSION TO DISTRIBUTION

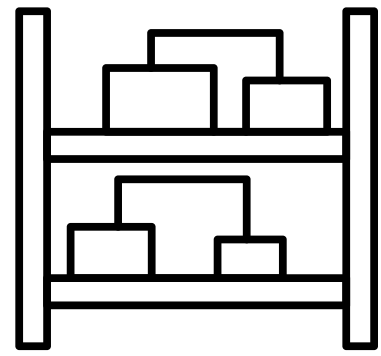

6,000

cells for profiles and components

& 1 robotic extrusion matrix accompanied
by standard robotic product handling
and distribution systems

ALUMINCO



QUALITY ASSURANCE & PRODUCTION CERTIFICATES

■ **ISO 9001:2015**

Quality Management System certified according to the international standard

■ **ISO 50001:2018**

Energy Management System certified according to the international standard

■ **ISO 14001:2015**

Environmental Management System certified according to the international standard

■ **ISO 45001:2018**

Occupational Health and Safety Management System certified according to the international standard

■ **EN15088:2005**

FPC - Factory Production Control System certified according to the international standard

■ **EN1090-1:2009**

FPC - Factory Production Control System certified according to the international standard

■ **QUALICOAT SEASIDE CLASS**

Certificate of Compliance for Coating of Aluminium Profiles.

■ **QUALICOAT QUALIDECO**

Certificate of Compliance for Decoration of coated Aluminium.

■ **QUALANOD**

Quality certification of the anodizing process.



ISO 9001:2015



ISO 14001:2015



ISO 45001:2018



EN 15088:2005



EN 1090-1:2009



ISO 50001:2018



TESTING CENTER CERTIFIED BY THE GERMAN INSTITUTE IFT ROSENHEIM.



As part of the development process, ALUMINCO's products undergo numerous tests that allow them to meet more stringent international standards. The ability to test new or existing systems in an in-house laboratory allows on the one hand the continuous and systematic control of the performance level of the systems and on the other hand the substantial support to partners for specific project tests.

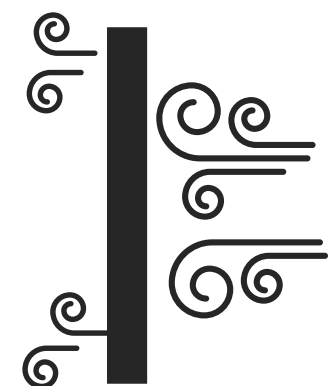

EN 1026

Air permeability

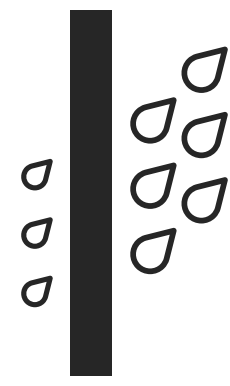

EN 1027

Water tightness

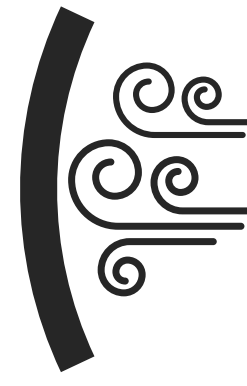

EN 12211

Resistance to wind load

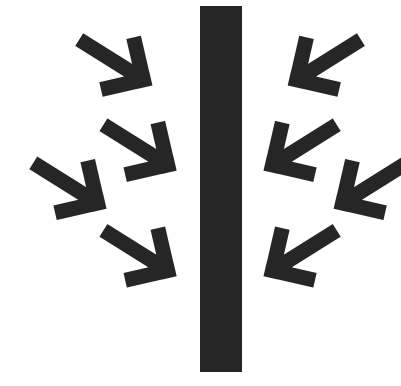

EN 12046-1

Operating forces



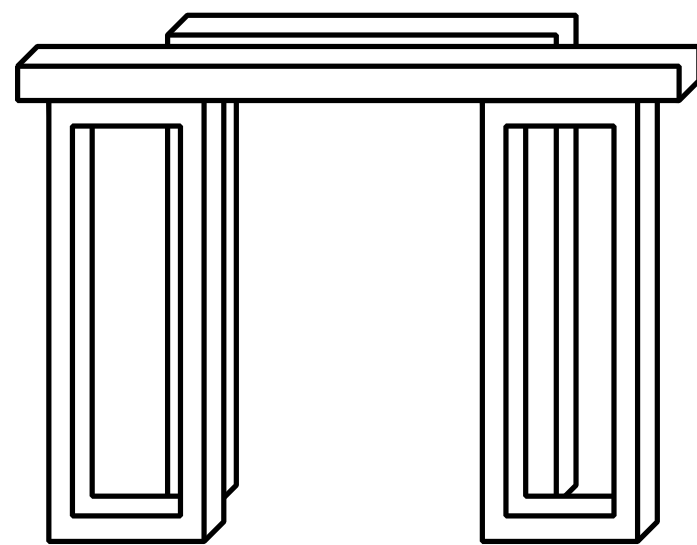

SLIDING SYSTEMS

SL320 • SL200 • SL2450
• SL2700 • SL2900

ALUMINCO



SL200

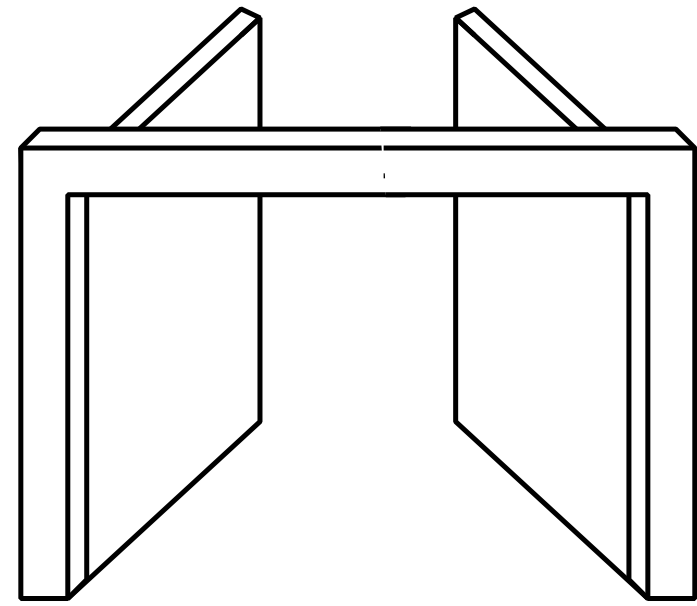

OPENING SYSTEMS

W400 • W540 • W450
• W4750 • W4900

ALUMINCO



W4750

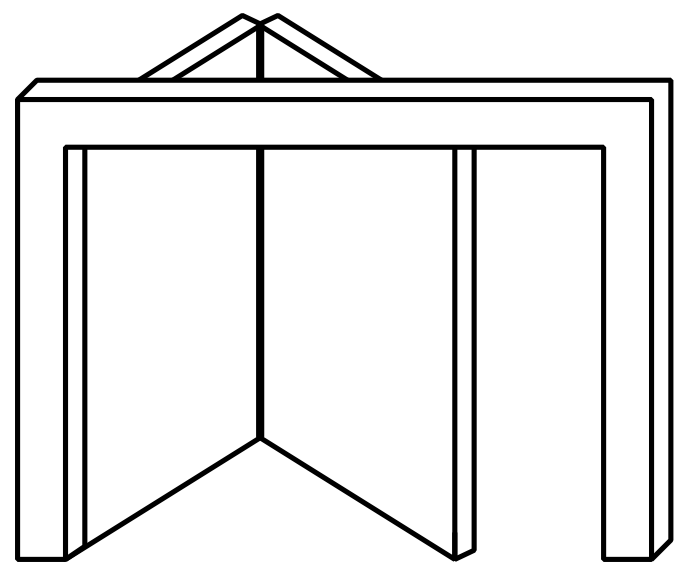

FOLDING SYSTEMS

FD460 • FD4600

ALUMINCO



FD4600

SKYLINE

PREMIUM SYSTEMS

CW35 • SL55 • SL55 • W85HS • W85ST

ALUMINCO

CW35



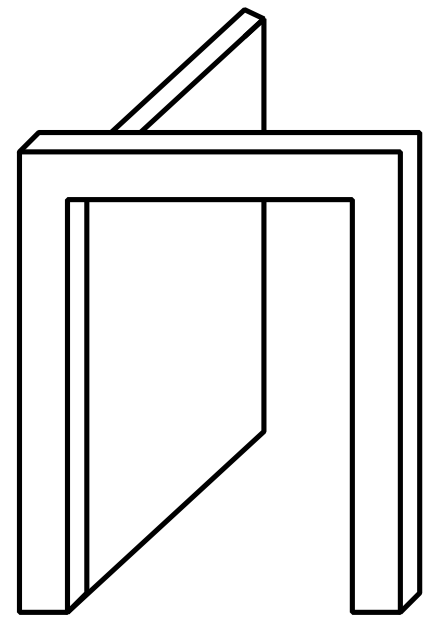

ENTRANCE DOORS

D110 • D75 • D95

ALUMINCO



D75

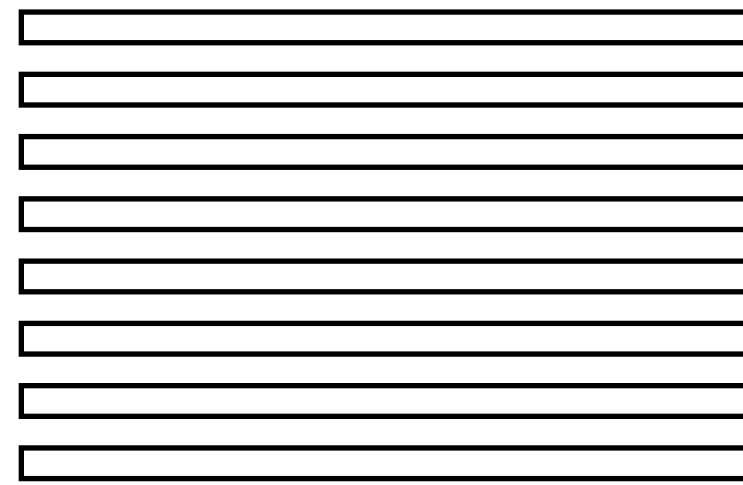

SHUTTER & SHADOW SYSTEMS

SH700 • SH3200 • SH3300 • SH3400

ALUMINCO



SH3400

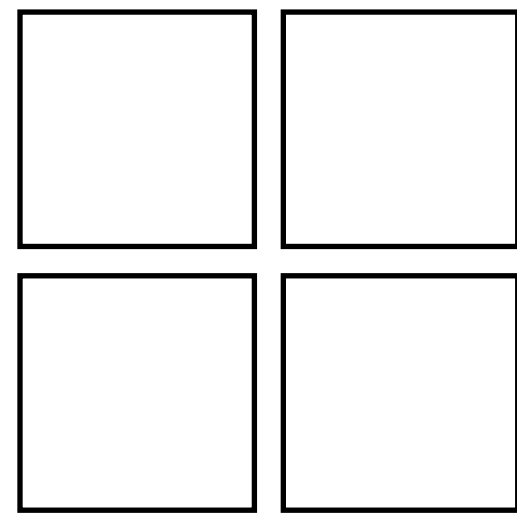

CURTAIN WALLS

EW50 • EW50SP

ALUMINCO



EW50

Crystalline[®]

railing system

Glass
Supporting
System

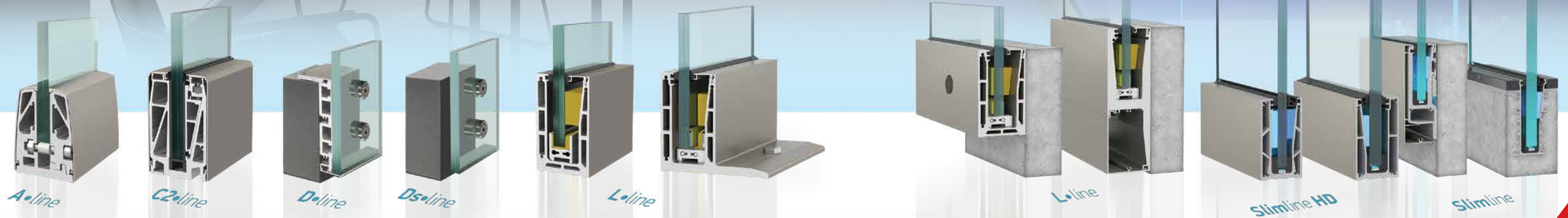

ALUMINCO

RAILINGS

CLASSIC LINE

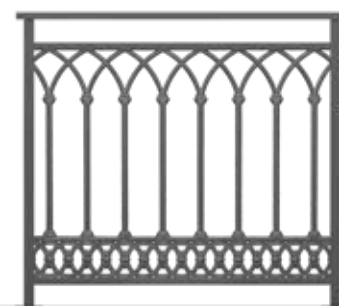
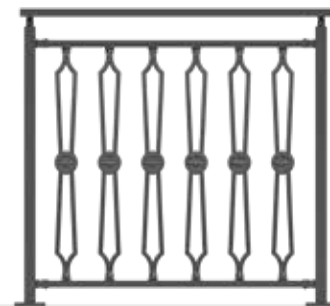
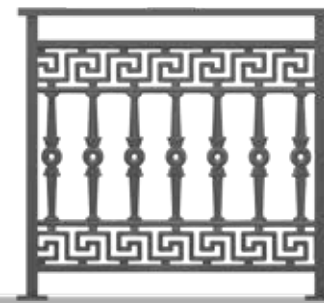

ALUMINCO

**Authentic cast lines
without restrictions**



RAILINGS



FUSION LINE



ALUMINCO



Timeless elegance and reliable safety in absolute balance

RAILINGS

Wild charm that goes beyond
the limits of imagination



ALUMINCO

RAILINGS





OUTDOOR

living

PERGOLAS

ALUMINCO





OUTDOOR
living

GATES

ALUMINCO





OUTDOOR
living

FENCES

ALUMINCO





PROJECTS

THESSALONIKI AIRPORT SKG

Building Category
Airports

Investment Company
Fraport

Aluminco Products
Façades

Location
Thessaloniki, Greece

Award
Aluminium in Architecture Awards

ALUMINCO





PROJECTS

PLOVDIV PLAZA

Building Category
Offices and Malls

Aluminco Products
Façades, Doors, Windows

Location
Plovdiv, Bulgaria





PROJECTS

SOHO CITY RESIDENTIAL & HOTEL

Developer
Soho Group

Building Category
Residential Apartments

Aluminco Products
Architectural Doors and Windows, Façade

Location
Bar, Montenegro

Area
16,000 m²

ALUMINCO





PROJECTS

THE NIDUS

Architects

Gonzalez - Malama Architects

Building Category

Residential Villa

Aluminco Products

**Architectural Doors and Windows,
Metal Skin Façade**

Location

Kalamata, Greece

Photo Credits

Panagiotis Voumvakis

ALUMINCO





PROJECTS

THE SYNTOPIA HOTEL

Building Category
Hotels

Aluminco Products
Doors, Windows

Location
Crete, Greece

ALUMINCO





PROJECTS

CABRITS RESORT & SPA KEMPINSKI DOMINICA

Partner

Range Developments

Building Category

Resort Hotel

Aluminco Products

Doors & Windows, Railings

Location

Dominica

Award

Caribbean Property Awards

ALUMINCO



OUR PURPOSE

In a particularly demanding and constantly evolving international environment, we remain loyal and united in a continuous dynamic of development, we shape our actions with respect to people and the environment, we move forward strongly towards the future we deserve. We are part of tomorrow and we must be the change we want to see in the world.

OUR MISSION

Is to contribute with our work to the safety and quality of life of all those who work at ALUMINCO, cooperate with us and those who are the end users of our products. To establish ourselves globally as a leading supplier of superior aluminium systems that meet modern architectural applications.

OUR VISION

Is to provide the international community of architects, designers, engineers, and fabricators with superior, innovative, energy efficient and environmentally friendly certified aluminium systems that incorporate top quality, high functionality and modern design standards.

OUR PEOPLE

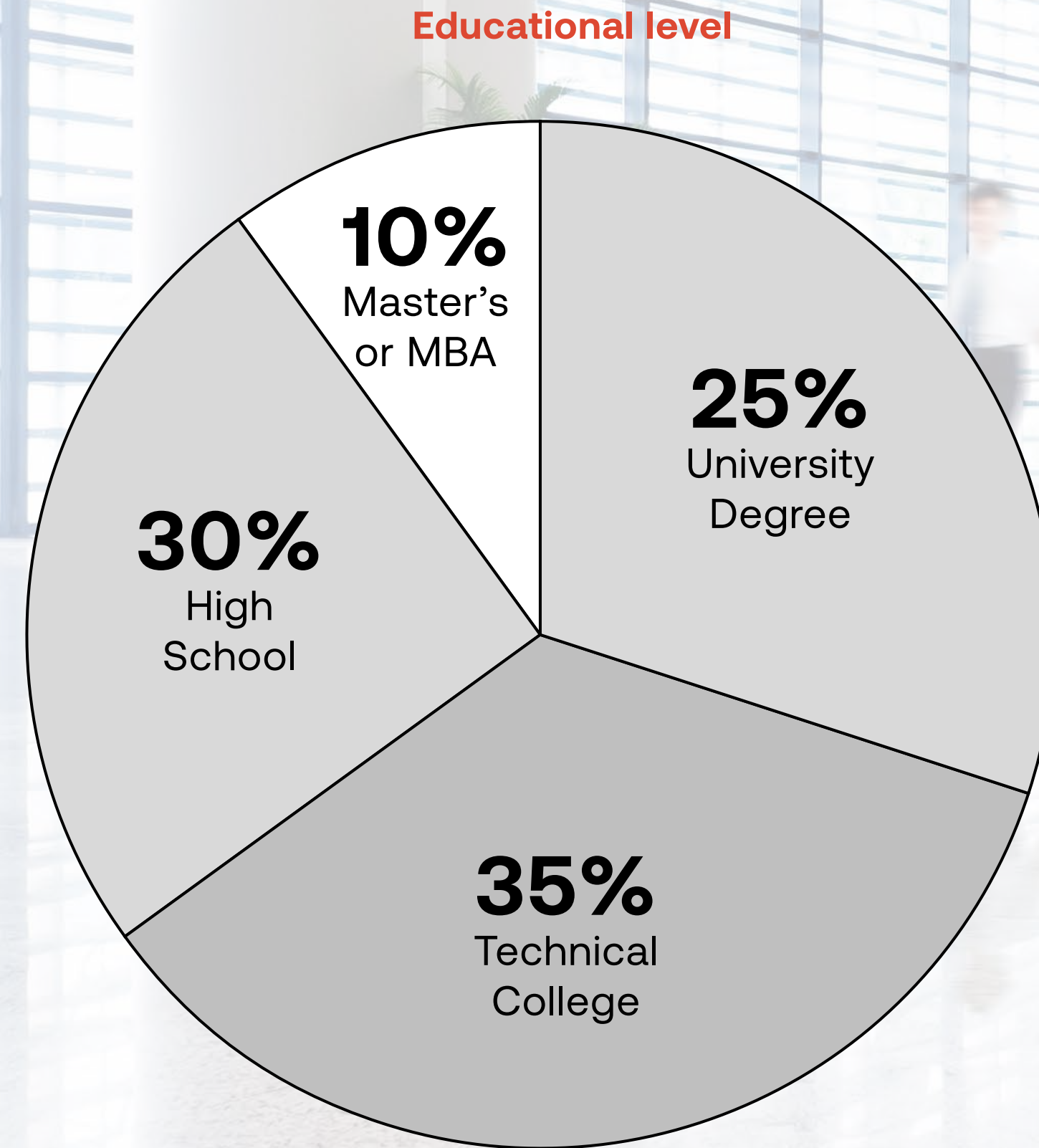
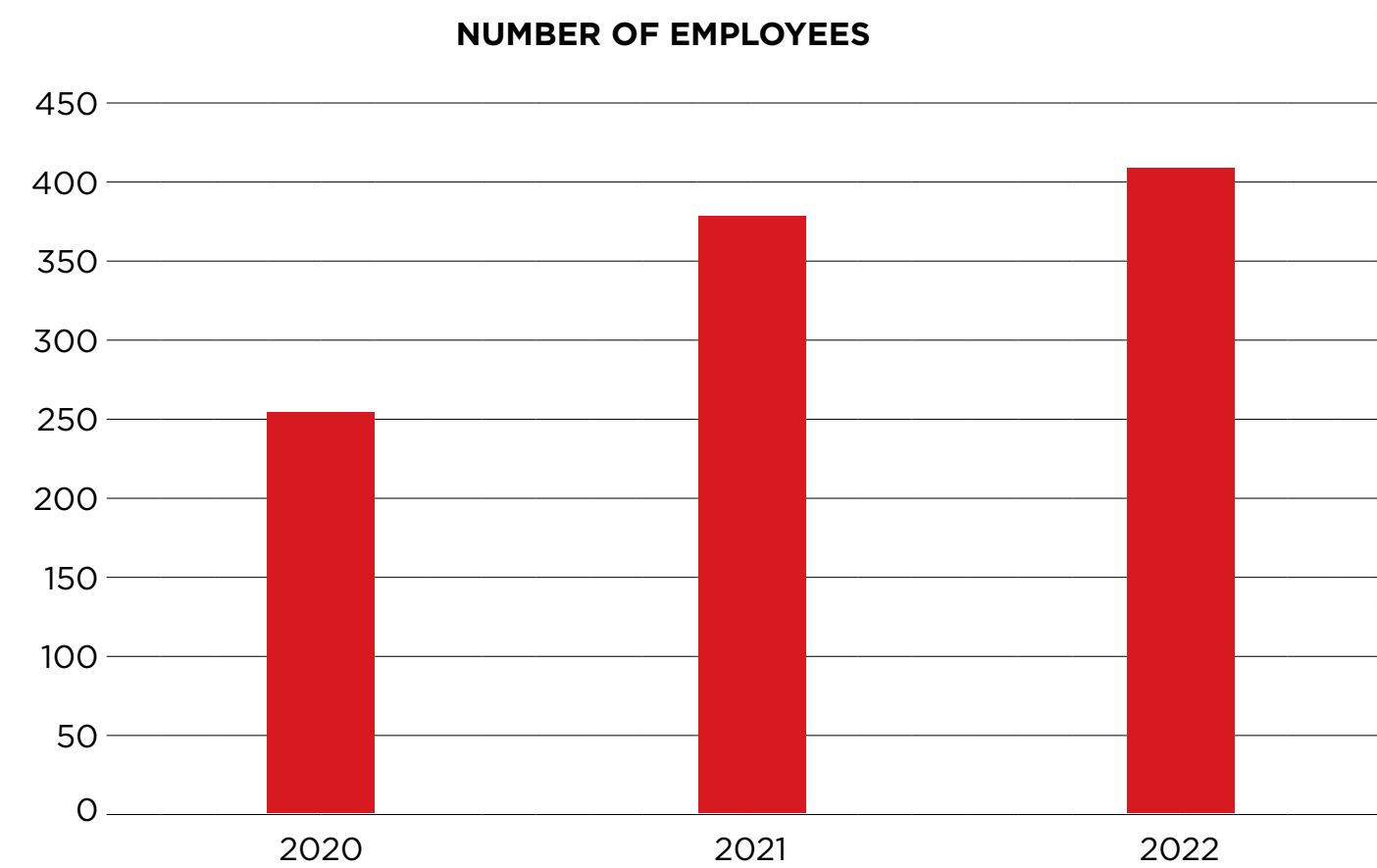

COMPREHENSIVE SERVICES & TOOLS

We provide a holistic support for architects, fabricators, investors and private clients, through cross-media services & tools that generate added value. A large range of tools and services is at our partner's disposal.

- Corporate website: www.aluminco.com

- Electronic periodic newsletters
- Product and corporate brochures



- Training seminars and technical workshops
- Demo assembly videos on YouTube

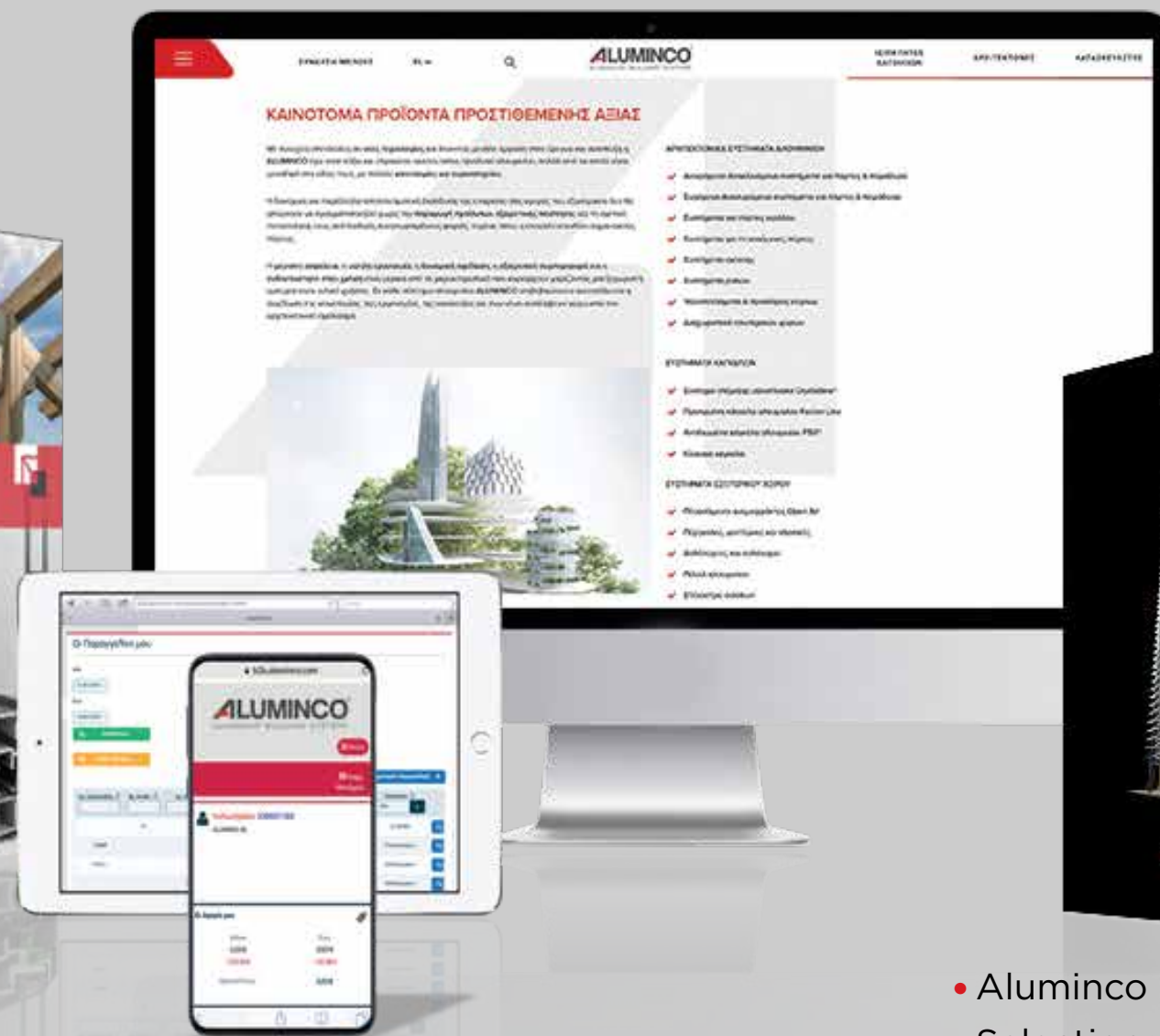

- MyAluminco B2B Platform, online ordering-configurator-costing-bidding



- Aluminco Selections Work Book



- Technical documentation
- Specification Product Data Sheets



- Engineering service for major projects



- Digital 3D printing and modeling



- Uw application for certified thermal calculation
- Integrated FP PRO software "All in one" and computational tools

- Performance tests in our Testing Center
- Drawings in AutoCAD and BIM files

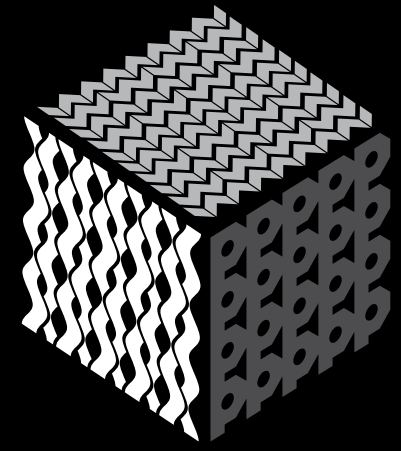

METAL SKIN[®]

Architectural Design Meshes

XPAND

Xpand is a new polymorphic, light, cost-effective architectural design mesh that adapts to your needs and is sure to rock your next project! It is available in a variety of forms, motives and colors that differ according to the given dimensions, the light penetration and the design.

PERFORATED

Perforated systems give endless choices on shapes and figures and actually let architects' spirit free for inspiration. A lot of indoor and outdoor applications on buildings in order to hide "blind" areas and to give space of architects' art! The 3D walling application gives space and life on the pattern!

WAVE

WAVE SYSTEMS follow actually the Xpand series, giving super privacy on the covered area! Wave systems will keep a high level of privacy and safety, mostly on outdoor application on fences and ceilings, doors and partitions for indoor ones.

HEXCEL

HEXCEL SYSTEMS give the opportunity for an additional selection on creative results! Hexcel is a special application with linear orientation by aluminum profile which can upgrade the project itself. Hexcel is a serious solution for demanding facades and fulfill as well the line of 3D walling systems.

Welcome a new world of possibilities!

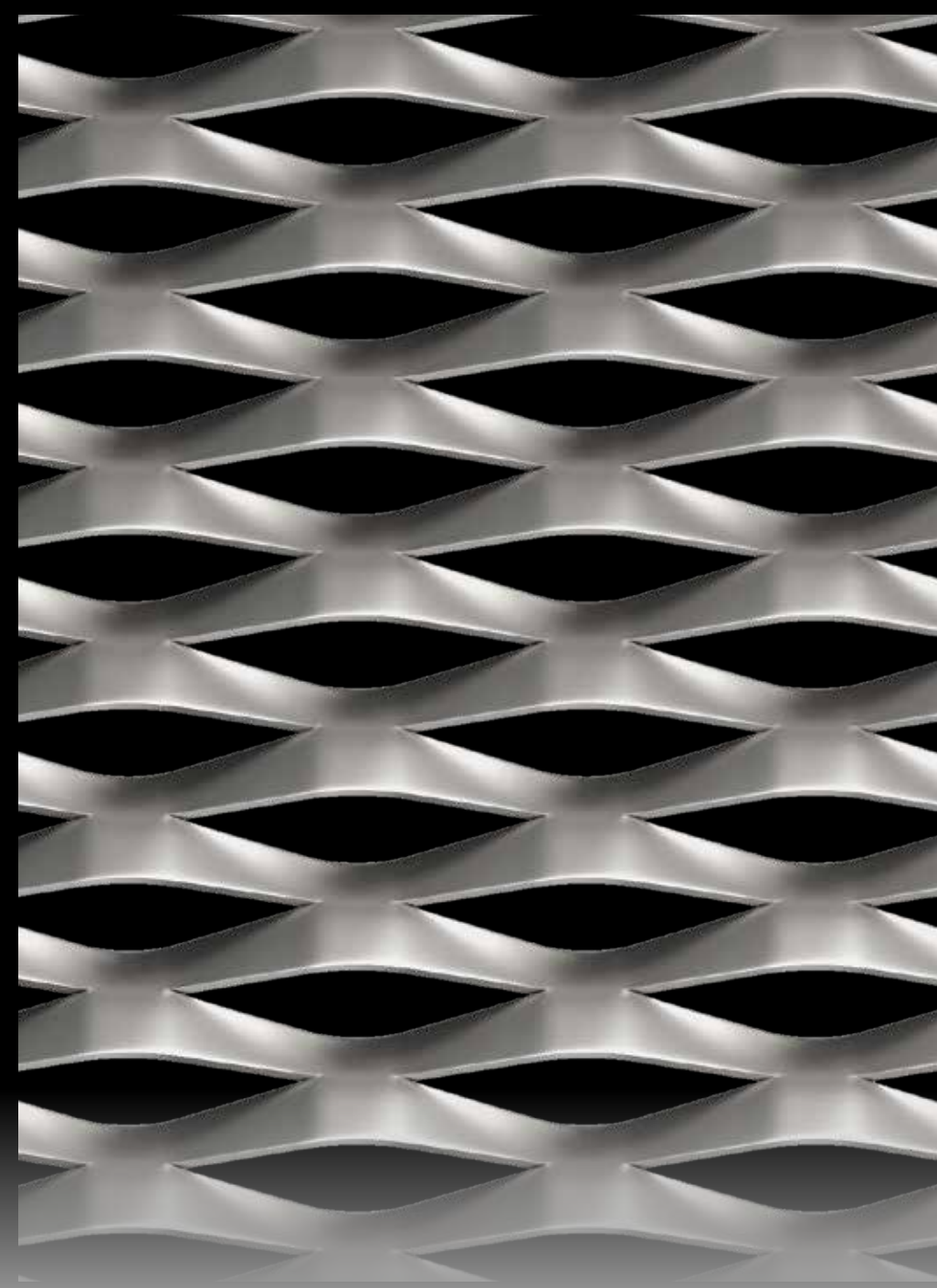
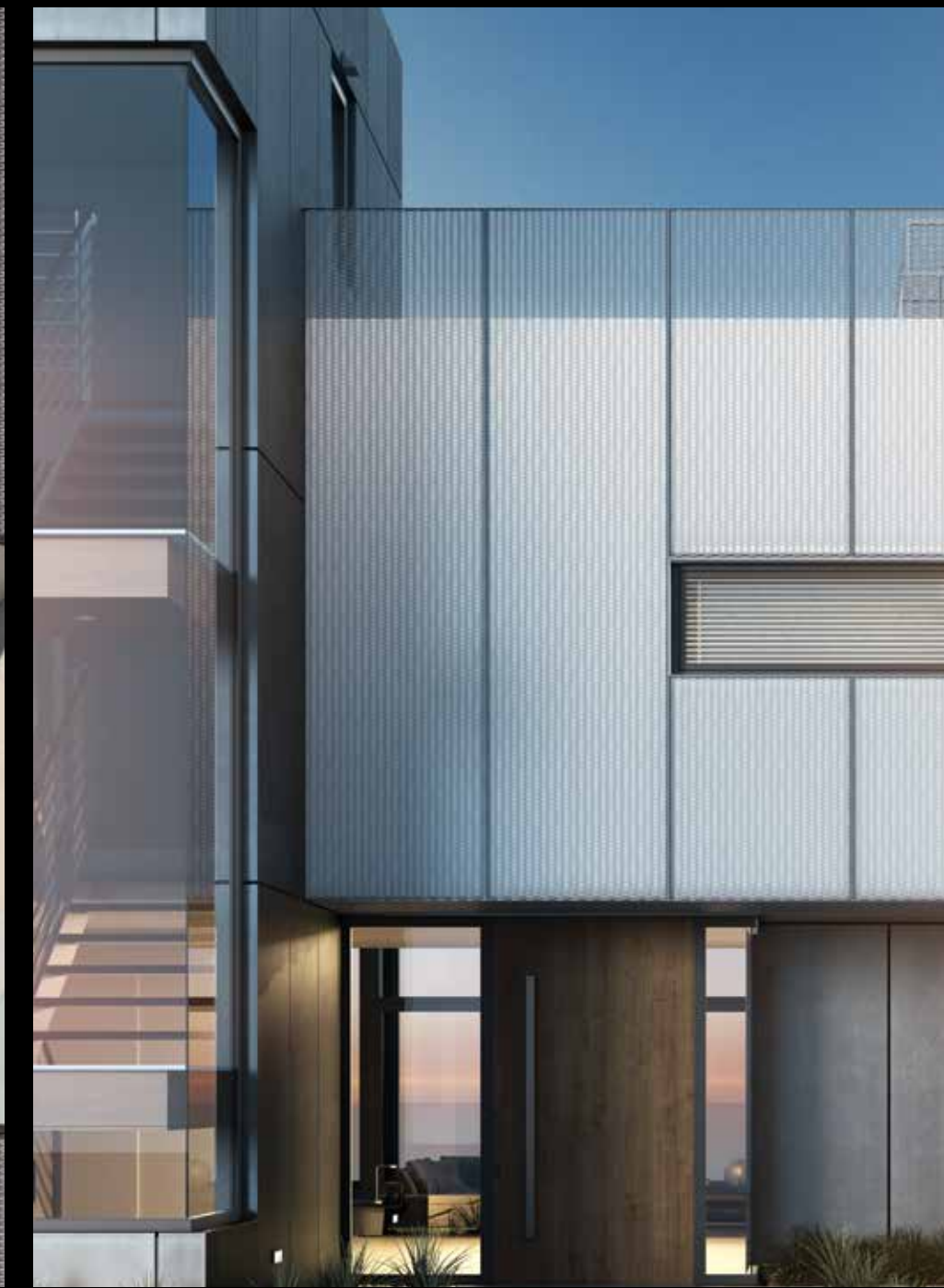
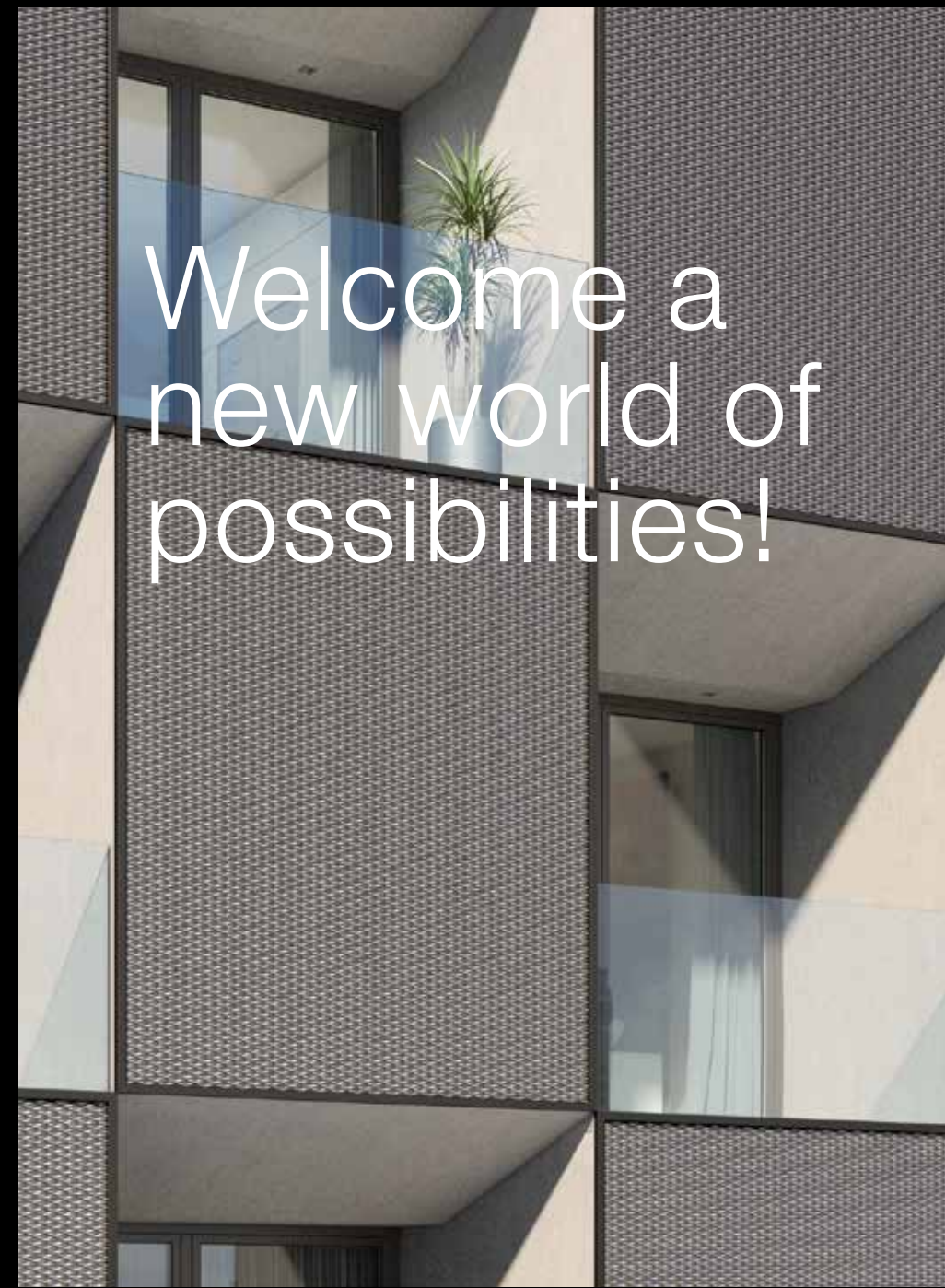

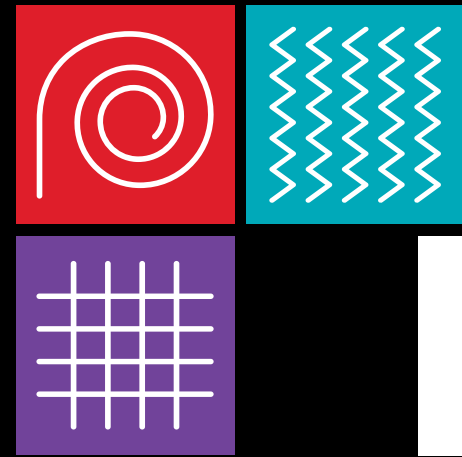

InScreen

INSECT SCREEN SYSTEMS

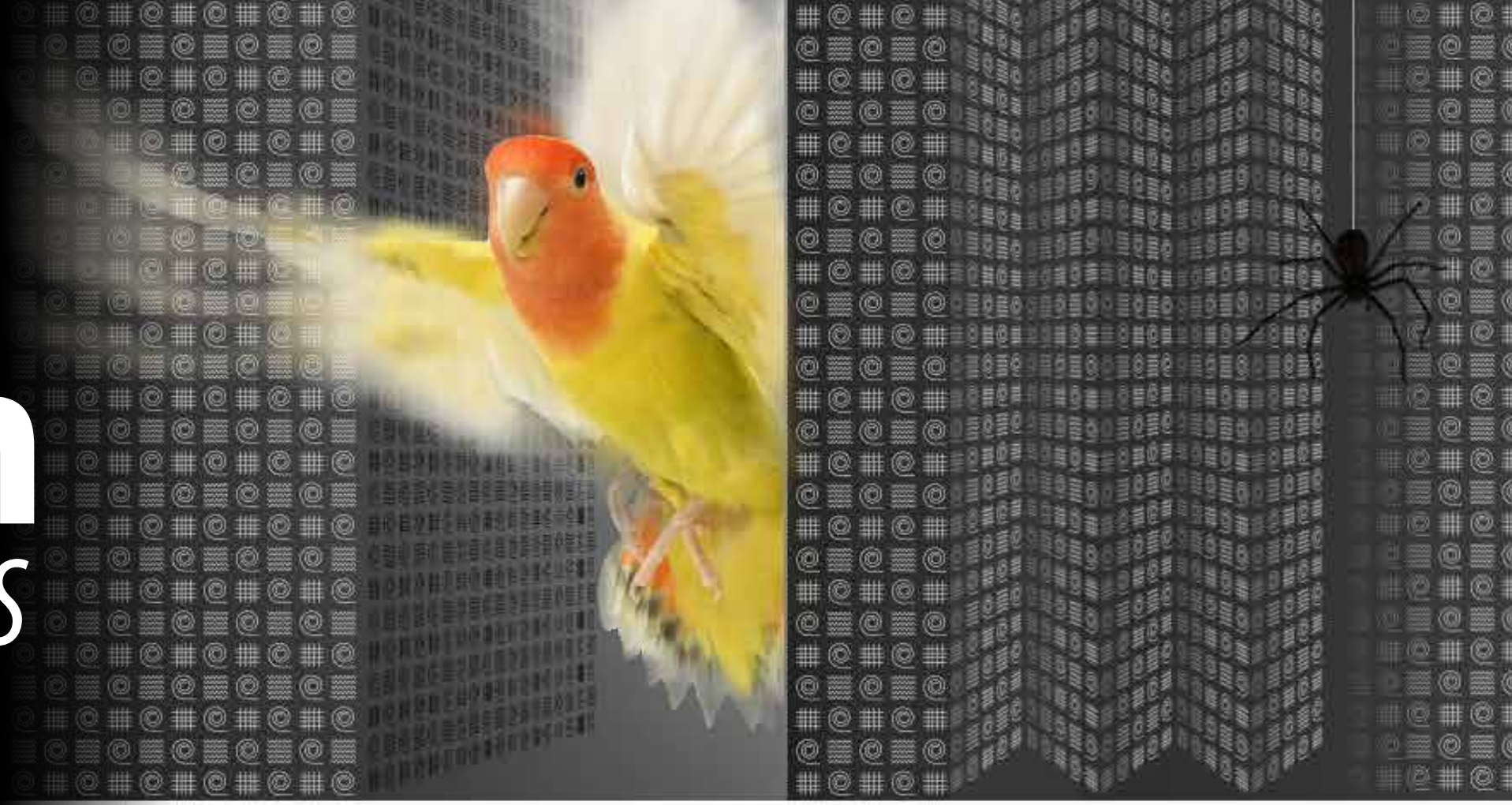

INTEGRATED INSECT
SCREEN SYSTEMS THAT
SET A NEW STANDARD
IN THE MARKET



InScreen was founded in 2016 and is a member of the Aluminco Group of Companies. It was created following the philosophy of extroversion, which embraces all Aluminco Group companies, and that is why, to this day, its products are used in major projects in more than 30 countries around the world.

Its main field of activity is the design, production, and distribution of upgraded insect screen systems, complying with the most demanding construction requirements. Excellent quality and innovative features, allow the InScreen insect screen systems meet the needs of today's markets.

With a turnover for 2021 that reaches 1,700,000 €, InScreen is one of the leading Greek companies that has strong presence around the world. 20% of its total turnover comes from export activities. Quality system ISO 9001 is applied and we are in the process of inclusion.

