



# SH3400

## Shadow System

Protection against solar radiation and controlling of the natural lighting of buildings.



## System Identity

The specially designed blinds have the option to be placed either horizontally or vertically, movable or fixed, depending on construction needs and current architectural trends.

Its core characteristic feature and competitive advantage is that the gap between the frame and blind is just 10 mm, satisfying completely every requirement for minimization of solar radiation.

## Features & Benefits

- A big variety of different widths and louvers is available.
- Louvers with Fixed or Adjustable inclination.
- Constructions in Horizontal and Vertical layout.
- Ease of mounting, assembly and disassembly.
- Cooperates with the Curtain Wall System EW50, Standard & Structural, by ALUMINCO.

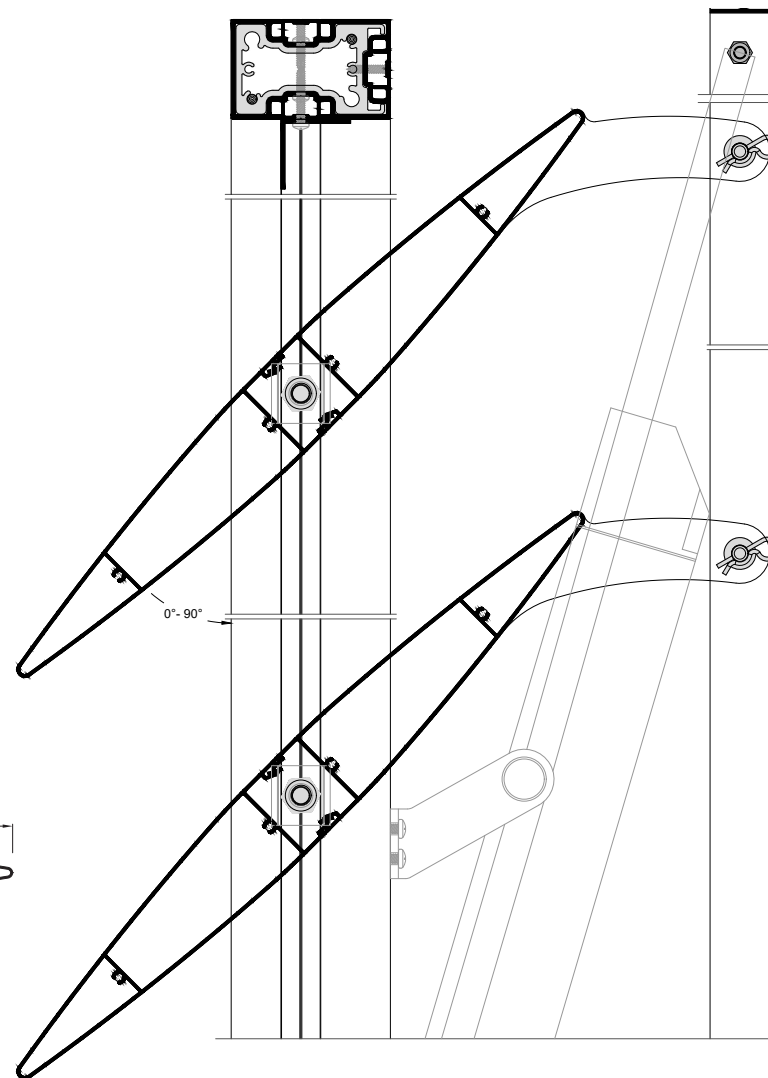
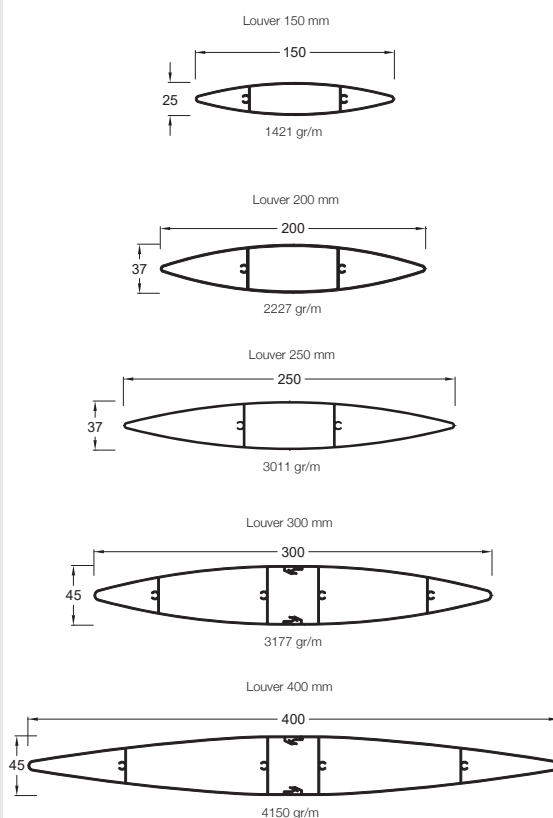

Elliptical design louver with adjustable incline

### CONFIGURATIONS

MOVABLE LOUVERS

FIXED LOUVERS

VERTICAL LOUVERS

HORIZONTAL LOUVERS

FIXED AND MOVABLE LOUVERS WITH CURTAIN WALL SYSTEM EW 50 STANDARD

FIXED AND MOVABLE LOUVERS WITH CURTAIN WALL SYSTEM EW 50 STRUCTURAL

### SYSTEM PROFILE DIMENSIONS

LOUVER'S FACE mm	37/45
LOUVER'S DEPTH mm	150-400
LOUVER WEIGHT Kgr/m	1.42-5.29

### LOUVERS' INCLINATION

FIXED LOUVERS: 0°-15°-30°-45°-60°

MOVABLE LOUVERS: MOTOR'S MOTION RANGE 0°-110°

### CONSTRUCTION DIMENSIONS

LOUVER'S SPAN mm	500-3500
------------------	----------

### PERFORMANCE (CALCULATED)

LOUVER 200 mm RESISTANCE TO WIND LOAD 1 KN/m<sup>2</sup> UP TO THE LENGTH OF 2300 mm INCLINE 90°

LOUVER 200 mm RESISTANCE TO WIND LOAD 1 KN/m<sup>2</sup> UP TO THE LENGTH OF 2800 mm INCLINE 45°

LOUVER 300 mm RESISTANCE TO WIND LOAD 1 KN/m<sup>2</sup> UP TO THE LENGTH OF 2800 mm INCLINE 90°

LOUVER 300 mm RESISTANCE TO WIND LOAD 1 KN/m<sup>2</sup> UP TO THE LENGTH OF 3400 mm INCLINE 45°